

## Χαρακτηριστικά



- Energiasäästev soojuspumbaga õhkkardin: Kulude ja CO2 heitkoguste vähendamise kuni 70% võrra (kütterežiim).
- Galvaniseeritud terasplaadist valmistatud isekandev konstruktsioon, on kaetud struktuurse epoksü-polüestrilise valge RAL9016 katega – standardne. Muu värvidega või roostevaba terasest katted on ka saadaval (soovi korral).
- Mikroperforeeritud sisselaskevõre filtreerimisfunktsioonidega (lihtne hooldus). Sisemine eelfilter on ka sees.
- Anodeeritud alumiiniumist väljalaskeavad, aerodünaamilise vormiga, iga külj on reguleeritav (0 kuni 15°).
- EC Double-inlet centrifugal fans driven by an external rotor motor and low noise level, with very low consumption efficiency fans.
- Sisemine eelfilter on ka sees.
- Only heating mode: Sees on 10-meetrine RJ45 kaabel ja infrapuna kaugjuhtimispuult.
- Cooling and Heating mode: Juhtpaneel CS-5DX-NE slave DX 5-kiiruselise selektoriga, 10m telefonikaabel on ka sees.
- DX VRF:  
Optional: Advanced Clever Control (programmable, automatic, intelligent, energy savings, Modbus RTU for BMS...) with special program to work in cooling mode which avoids water condensation. It regulates cooling power to maintain air speed and get the environments separation.  
Ready to connect to MIDEA VRF outdoor heat pump unit (R410A), not included, the customer should purchase it.  
Requires DX Interface KIT with expansion valve adapted for air curtain, please consult.

## Προδιαγραφές

50Hz

Μοντέλο	Ονομαστική ροή αέρα (m <sup>3</sup> /h)	Συνιστώμενο ύψος εγκατάστασης (m)
BB 1500 VRF24-MD	4680	4-7
BB 2500 VRF43-MD	8190	4-7
BB 3000 VRF47-MD	9360	4-7

60Hz

Μοντέλο	Ονομαστική ροή αέρα (m <sup>3</sup> /h)	Συνιστώμενο ύψος εγκατάστασης (m)
BB 1500 VRF24-MD	4680	4-7
BB 2500 VRF43-MD	8190	4-7
BB 3000 VRF47-MD	9360	4-7

ΔΙΑΣΤΑΣΕΙΣ

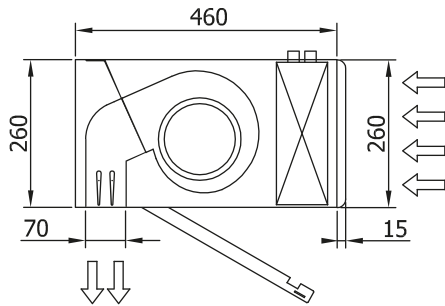

L	A	B
1000	920	-
1500	1420	710
2000	1920	960
2500	2420	1210
3000	2920	1460